

SALES DRAWING

SALES DRAWING

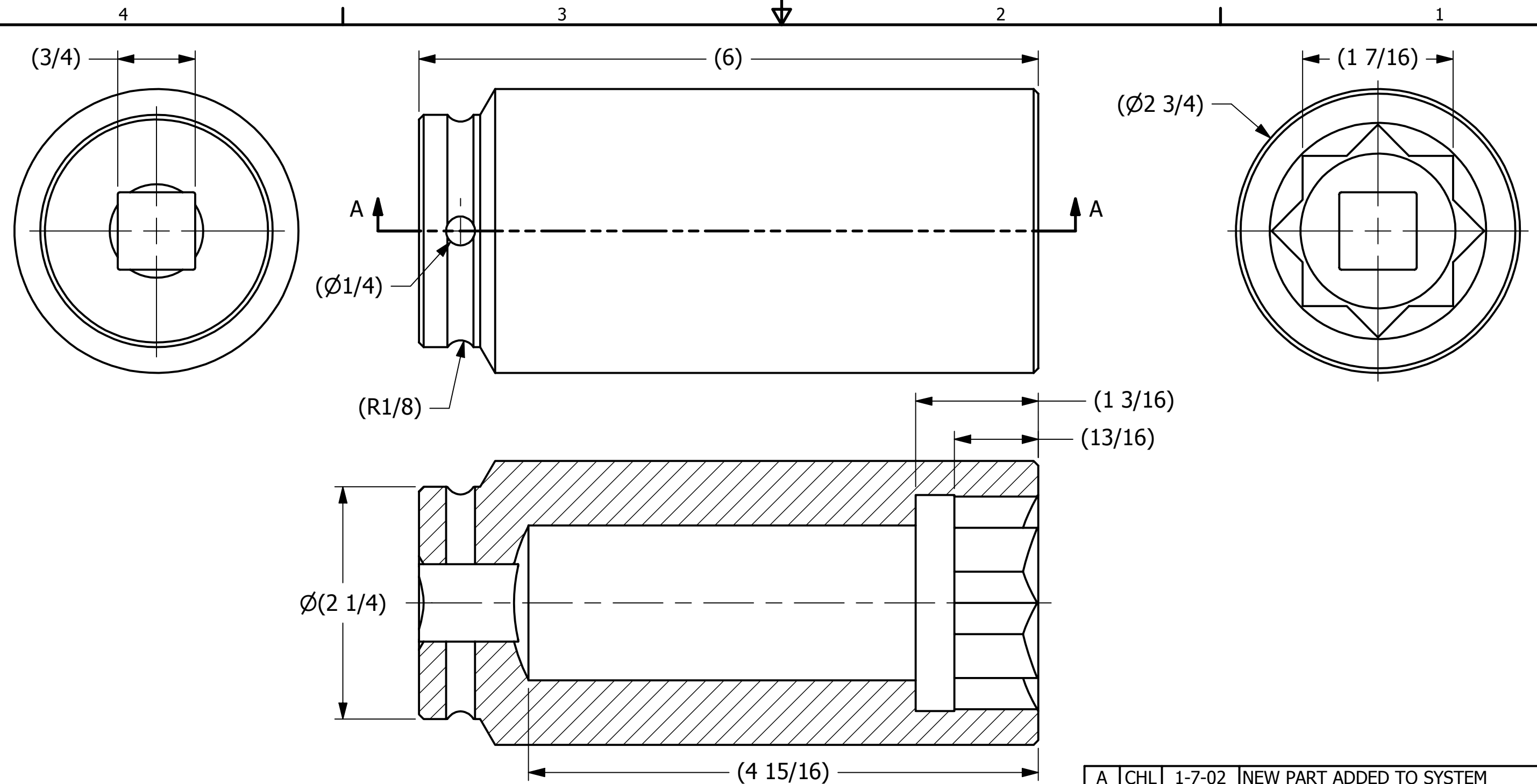

SECTION A-A

A	CHL	1-7-02	NEW PART ADDED TO SYSTEM
REV	BY	DATE	DESCRIPTION
<b>SALCO PRODUCTS, INC.</b>			
PART NAME: <b>SOCKET 1 7/16"X6" DOUBLE SQUARE</b>			
MATERIAL: <b>4140 STEEL W/BLACK OXIDE FINISH</b>			
PROJECT #: <b>010815</b>		SHEET #: <b>1 OF 1</b>	SCALE: <b>1:1</b>
DRAWING #: <b>B16444</b>		PART #: <b>SKT1716</b>	

<small>UNLESS OTHERWISE SPECIFIED DIMENSIONAL TOLERANCES</small> FRACTIONAL: ±1/16 X.XX: ±.03 X.XXX: ±.015 ANGULAR: ±1° <small>DEBURR ALL SHARP EDGES. ALL MACHINED SURFACES TO HAVE A 125 RMS FINISH UNLESS NOTED OTHERWISE.</small> <small>THIRD ANGLE PROJECTION</small>	DRAWN BY:	CHL
	CHECKED BY:	SAB
	PROTOTYPE BY:	CHL
	PROTOTYPE DATE:	1/7/2002
	APPROVED FOR PRODUCTION BY:	SAB
	PRODUCTION DATE:	1/7/2002

THIS PRINT, PROPERTY OF SALCO PRODUCTS INC., CONTAINS PROPRIETARY INFORMATION AND MUST NOT BE COPIED, REPRODUCED, OR USED DETRIMENTALLY TO OUR INTEREST.